

# Centurion<sub>100</sub>

## CaseTaper

**Semi-automatic uniform case sealer reduces labor and consumables costs, while increasing productivity.**



**The economical choice for applications requiring infrequent box size changes.**

The Centurion 100 Case Sealer is a cost-effective top and bottom case taper for sealing large runs of uniform cases, or those that require infrequent case size changes.

The Centurion 100 applies stripes of pressure sensitive tape to both the bottom and top center seam of the case simultaneously. As the case passes through the machine, rubber rollers wipe down the tape top and bottom. The securely sealed case is automatically discharged and ready to seal another case.

**ABAL**  
Manufacturing Division  
A division of LOVESHAW

# Centurion<sub>100</sub>

## Case Tapers

Abal Manufacturing has over fifteen years of experience in building case tapers designed to seal the top and bottom of corrugated cases. Any company who packages its products in corrugated cases can experience the many benefits of owning a Centurion Series case taper.

- ┆ Enhanced product appearance
- ┆ Enhanced product security
- ┆ Increased productivity
- ┆ Reduce factory costs
- ┆ Reduce maintenance costs

The Centurion model 100 Case taper is a semi-automatic machine made to run boxes of uniform size. Change over can be made easily for a different batch run.

The model 100 features a MK V tape heads, which are interchangeable top and bottom. Among the many innovations in the design of the MK V tape head are: a preset one-way function roller which eliminates the need for manual release tension adjustment; conical roller tape presentation which prevents the tape from sticking to itself; knife blade guards for maximum safety; high tech bearing materials that do not allow adhesive build-up and heavy gauge materials that ensure long life of all components.

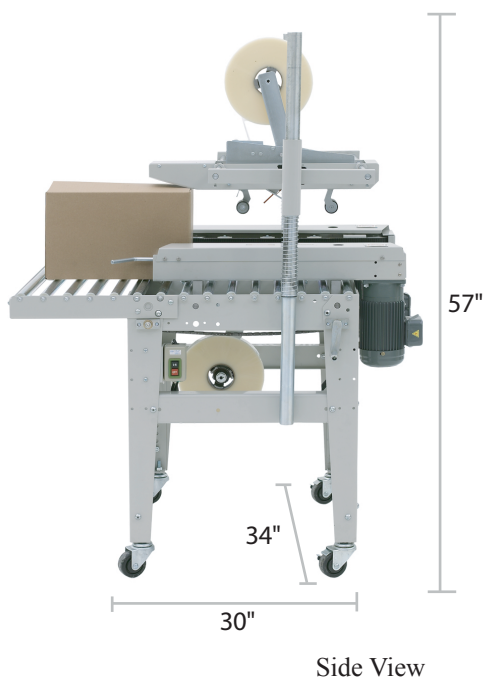

### Model 100 Specifications

#### Case size range:

- Length: 6" to unlimited
- Width: 4.5" to 20"
- Height: 3.75" to 20"
- \* Note Model 125U offers width to 25"

#### Speed:

- Belt speed 85 fpm

#### Electrical:

- Two 1/6 hp motors
- 110v, single phase, 60 cycles; 7.6 amps

#### Work Height:

- 28" to 36"

#### Machine Weight:

- 230 lbs.

#### Model 100 Features:

- ┆ Double column construction eliminates lateral and vertical wear
- ┆ Roller bed eliminates excessive wear created by friction
- ┆ Sidebelt drive
- ┆ MK V tapeheads
- ┆ Adjustable machine height from 28" to 36"
- ┆ Self-centering belts
- ┆ Comes with the infeed table

Please consult factory for the many options available to customize the Centurion case tapers.

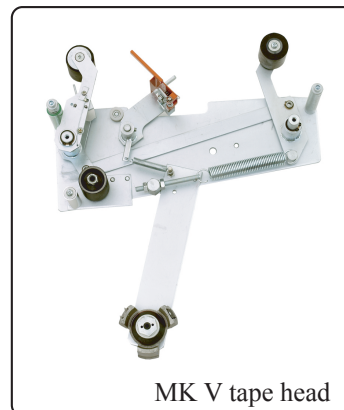

**ABAL**  
Manufacturing Division  
A division of LOVESHAW